

## 10000 Vibration Test System

Lansmont's Model 10000 Vibration Test System was designed for heavy payloads with large dimensions. If you are looking for a system which will handle heavier payloads than our 1800 vibration test system, and the dimensions of your test specimen(s) exceed the table limitations of our Model 7000, then our Model 10000 could be ideal. The 10000 features a rugged hydraulic actuator designed specifically for today's testing profiles, a reliable hydraulic power supply, and Lansmont's extremely popular TouchTest vibration control system. Let Lansmont help you configure a Model 7000 vibration test system that will meet your demands day!

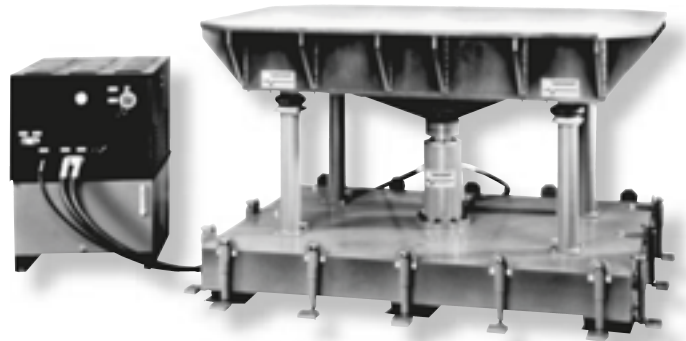

shown with a 60 x 90 inch table

### 10000 Features:

- Extremely versatile, the 10000 can be configured with table sizes from 36 in. square (91.4 cm) to 60 in. x 98 in. (152 cm x 249 cm). It has a piston stroke of 2.5 in. (6.4 cm) and can handle payloads up to 6,000 lbs (2727 kg).
- Windows™ based vibration control system, including Lansmont's extremely powerful TouchTest Vibration software.
- Random vibration, swept-sine vibration, resonance search and dwell, repetitive bounce and powerful user-defined profiles all included.
- Fully integrated pump and servo controls, all designed and manufactured by the Lansmont Corporation.
- Field-to-Lab® ready. Simple transfer of data from your Lansmont SAVER™ to your vibration controller for real-world random vibration tests.
- Full range of applications training programs available.
- Worldwide Customer Service department.



### Vibration Testing Benefits:

- Identify design and production defects.
- Increase product ruggedness.
- Reduce packaging costs.
- Eliminate shipping damage.



# 10000 Vibration Test System

## TECHNICAL SPECIFICATIONS

PHYSICAL	
Table Sizes	36 in. sq. (91 cm) – 60 in. x 98 in. (152 cm x 249 cm)
Seismic Base Options	8,000 lbs. (3,629 kg) – 13,500 lbs. (6,123 kg)
PERFORMANCE	
Load Capacity, Maximum	3,500 lbs. (1,588 kg)
Load Capacity, Maximum (with optional 1-G Supports)	4,850 lbs. (2,200 kg) *(See Plant Air)
Maximum Stroke (Peak-To-Peak)	2.5 in. (6.4 cm)
Frequency Range	3 – 300 Hz
Actuator Stall Force at 3,000 psi (207 bar)	12,370 lbs. (55 kN)
HYDRAULIC POWER SUPPLY	
Voltage	200 – 460 VAC
Frequency	50 – 60 Hz
Phase	Three Phase
HPS Motor Rating	20 HP, Standard
POWER REQUIREMENTS, CONTROL	
Voltage	100 – 220 VAC
Frequency	50 – 60 Hz
Phase	Single Phase
ENVIRONMENTAL	
Cooling Water	60 Degrees F at 6 Gal/Min. for Models 1800 – 10000 (15.5 Degrees C at 22.7 L/Min. for Models 1800 – 10000)
Plant Air (*)	100 psi (6.9 bar) for all Vibration Machines utilizing the 1-G Support option.

### TouchTest Vibration Controls:

- Available in either Bench-Top or Full "System Station" Configurations. Both Options have identical functionality; the System Station offers a convenient, stylish enclosure for controls.
- Extremely powerful, Windows™ based software.
- Reliable, fully-integrated pump/servo controls.
- Intuitive interface and full-featured help files make machine operation simple.
- Quick, easy data upload from Lansmont field data recorders makes Field-to-Lab® simulations a snap.
- Easy sharing of data via e-mail, internet, and export to other popular programs such as Word™ and Excel™.



**Lansmont**  
Corporation